

ALTA ADVANTAGES

- Integration with existing plant infrastructure
- Synchronize process data with machine dynamic data
- Off-Line analysis without having to re-capture data
- Real-Time data Collection
- Advanced vibration and transient analysis
- Intelligent alarming
- Cybersecure

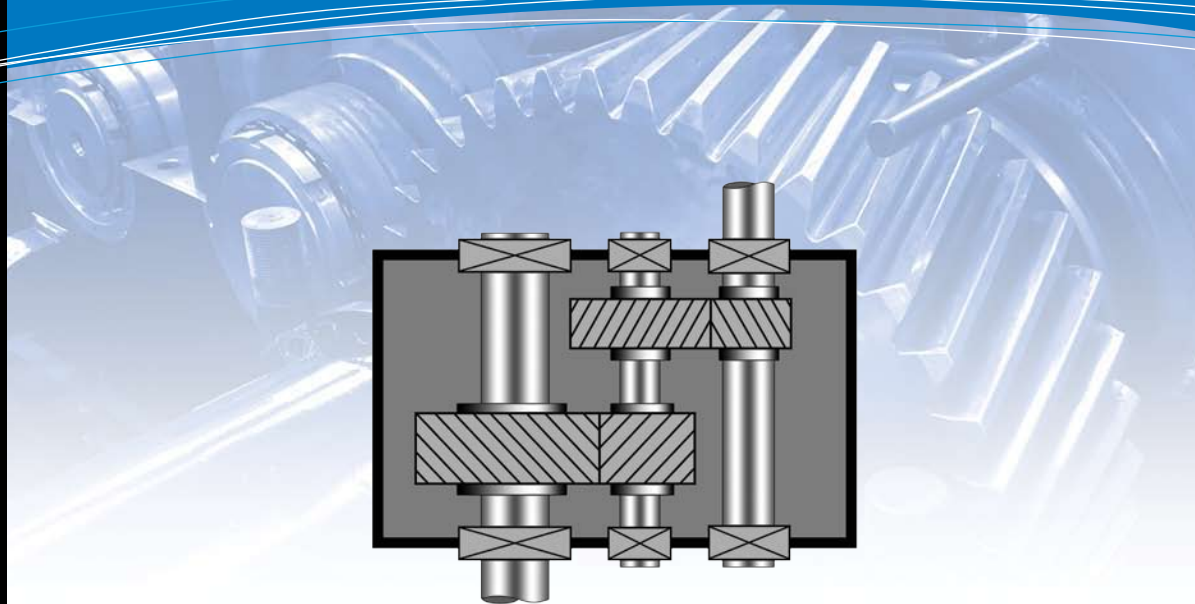

With Alta Solutions GAP Free collection you won't miss a beat.

Monitor, Analyze, and Protect your assets from common faults:

PUMPS: Critical, Structural Resonances, Impeller Eccentricity, Impeller Imbalance, Impeller/Diffuser Clearance (gaps), Recirculation (low flow), Cavitation (low suction head), Oil Whirl, Wear Ring Clearance, Lubrication Loss, etc.

MOTOR: Bearing Faults, Air Gap Variation, Broken Rotor Bars, Eccentric Motor, Stator Flexibility, Off Magnetic Center, Stator Shorts

COMBINED: Mass Imbalance, Misalignment, Shaft Bow, Coupling Lockup, Thermal Variability, Distortion, etc.

ADVANCED CONDITION MONITORING SYSTEM



- Advanced Machine Analysis
- Powerful Transient Data Collection
- Seamlessly Plant Intergration
- Built-In Flight Data Recorder

Additional Features:

- Machine Data Collection
- Industrial Chassis
- Plant Interfaces
- Sensor Support

API 670 COMPACT MACHINERY PROTECTION SYSTEM



- API 670 5TH Edition Compliant Integrates
- Powerful Machine Analysis
- Modular System for Easy Upgrading and Replacement
- Supports for Multiple Standard Plant Interfaces
- Easy to Install and Maintain.
- Built-In

API 670 MPS WITH ADVANCED CONDITION MONITORING



- API 670 5th Edition Compliant
- Integrates Powerful Machine
- Analysis Modular System for Easy Upgrading and Replacement
- Uses Standard and Common Wiring Connectors
- Support for Multiple Standard Plant Interfaces
- Easy to Install and Maintain

 **Alta Solutions**
 Alta Solutions Incorporated
 12580 Stowe Drive
 Poway, CA. 92064 USA
 Toll-Free: (877) 258-2765
 Email: sales@altasol.com
 Web Site: www.altasol.com

